

RoHS

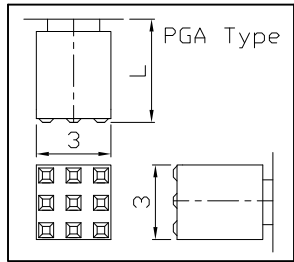
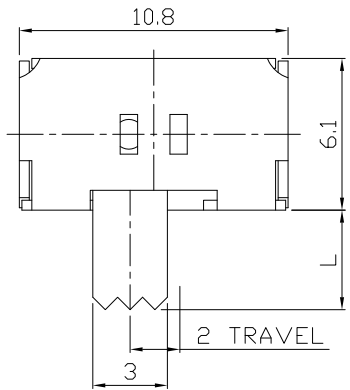

MODEL CODE

SK-22D02-GEI

Knob Type
GEI
PGA

L(mm)
~

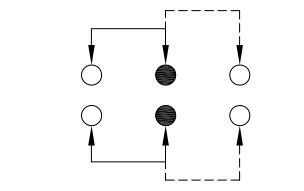

CIRCUIT DIAGRAM

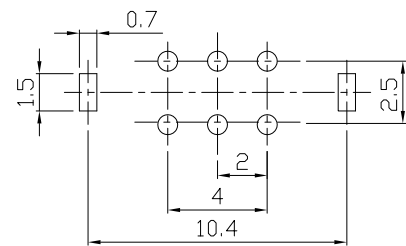
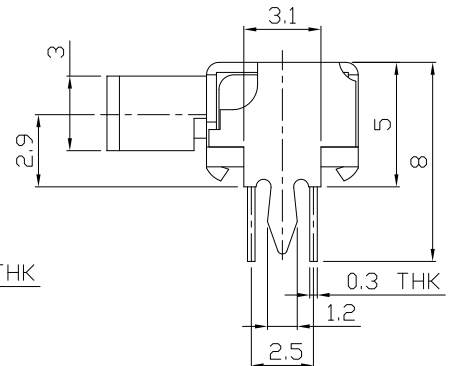
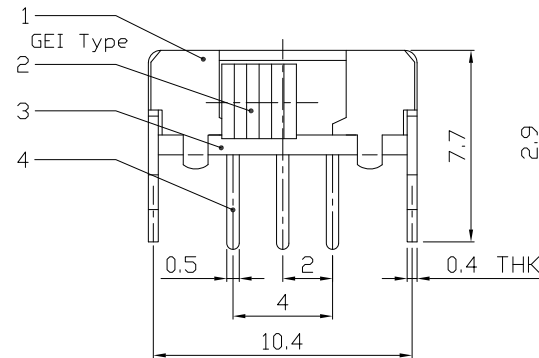

P.C.B LAYOUT  
BOTTOM VIEW

Height(高度) :

NO.1	
PART NO	L
	X

Main technical specifications:

Rated load(额定负荷):	DC 50V 0.3A		
Contact impedance(接触阻抗):	100m MAX		
Insulation impedance(绝缘阻抗):	100M MIN		
TIMING	NON-SHORTING		
OPERATING LIFE(电气寿命):	100,000 cycles		
Usage temperature(使用温度):	-25 to 85		
CIRCUIT	2P2T		
Trip(行程):	2.0±0.2mm		
Operating force(操作力):	1	2	250±100gf
	3	4	
	5	6	

public errand(公差) : ±0.2mm unit(单位) : mm

LCZY ELECTRONICS(SHEN ZHEN)CO.,LTD

PART NAME		SWITCH		DRAWING	G.L CHEN	DWG.No.	LCZY
PART NO.		SK-22D02		CHECK	Z.LIU	REV.	A1
UNIT :	TOLERANCE	OTHERWISE	UP TO 5	ANGLE	APPROVAL	DATE	SK-09-2019
			±0.2				
mm			ABOVE 5~30		SCALE	PAGE	1 OF 1
			±0.3		2:1		
			ABOVE 30				
			±0.5				
			±3'				

COPYRIGHT RESERVED,PLEASE DO NOT COPY.

SK-22D02-