

RoHS

Height(高度) :NO.1

9.0	J	15.0	T
8.5	I	14.5	S
8.0	H	13.0	R
7.5	G	12.5	Q
7.0	F	12.0	P
6.5	E	11.5	O
6.0	D	11.0	N
5.5	C	10.5	M
5.0	B	10.0	L
4.3	A	9.5	K
高度H(mm)	X=	高度H(mm)	X=

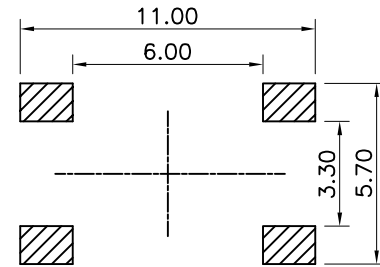
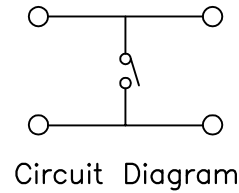
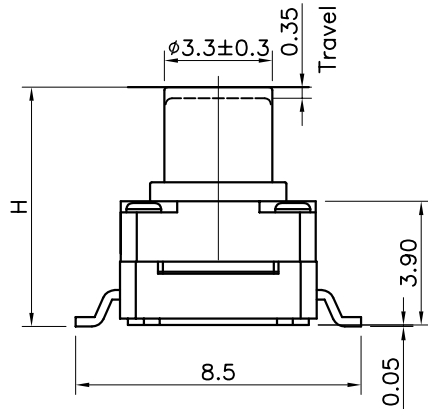

PCB Layout(Pattern side)

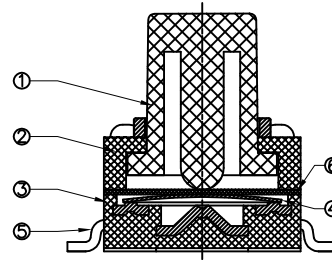

Material: 防水等级IP67

Button 按钮	PBT/LCP
Cover plate 盖板	PBT/LCP
Shrapnel 弹片	不锈钢(复银)
Base 基座	PBT/LCP
Pin 引脚	磷铜(镀银)

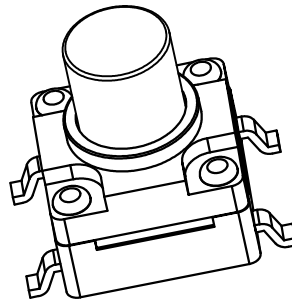
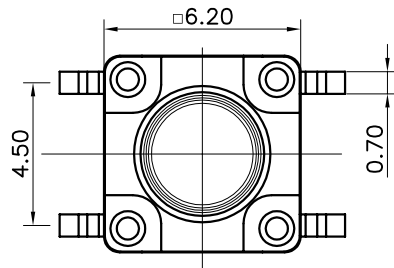

NOTE:Waterproof:IEC IP67

Main technical specifications:

Rated load(额定负荷):	DC 12V 50mA
Contact impedance(接触阻抗):	100m MAX
Insulation impedance(绝缘阻抗):	100M MIN
Welding resistance temperature(耐焊温度):	250 ± 5 ° 5s
OPERATING LIFE(电气寿命):	100,000 cycles
Usage temperature(使用温度):	-25 to 85
Operating humidity(使用湿度):	85% RH
Trip(行程):	0.35 ± 0.1mm
Operating force(操作力):	1 90 ± 30gf 2 130 ± 30gf
	3 180 ± 50gf 4 250 ± 50gf
	5 350 ± 50gf 6

public errand(公差) : ±0.2mm unit(单位) : mm

NO.2

LCZY ELECTRONICS(SHEN ZHEN)CO.,LTD

PART NAME		SWITCH		DRAWING	G.L CHEN	DWG.No.	LCZY
PART NO.		K2-1839SP		CHECK	Z.LIU	REV.	A1
UNIT :	TOLERANCE	OTHERWISE	UP TO 5	ANGLE	APPROVAL	DATE	K2-09-2019
			ABOVE 5~30				
mm			ABOVE 30		SCALE	PAGE	1 OF 1
			ANGLE		2:1		

COPYRIGHT RESERVED,PLEASE DO NOT COPY.

K2-1839SP- -