

RoHS

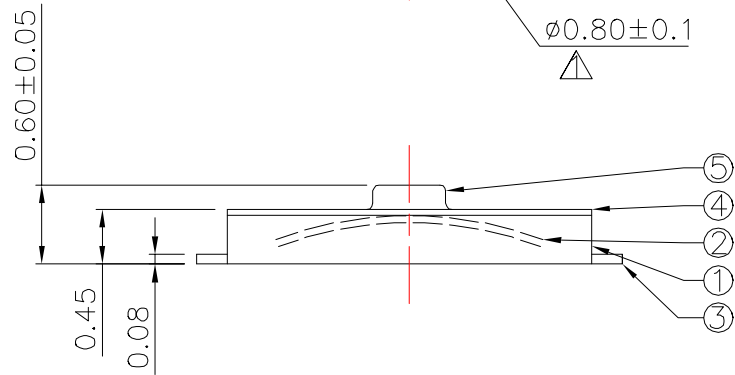
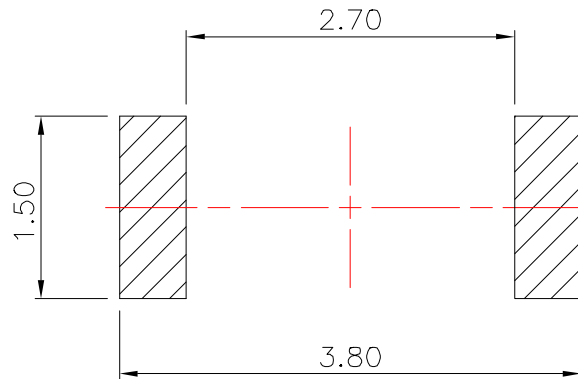
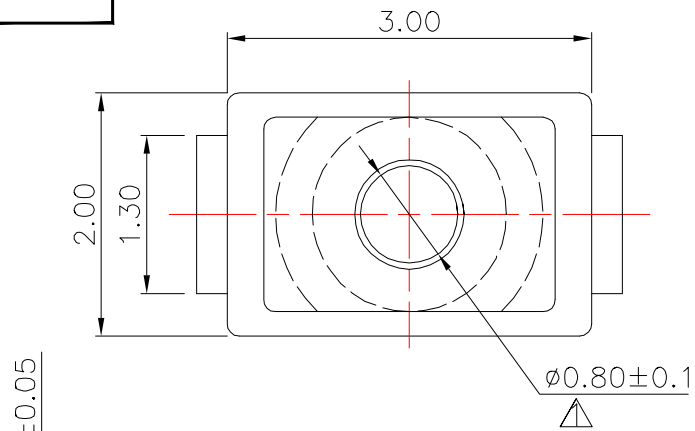

PCB Layout (Pattern Side)

Height (高度) :

NO.1	
PART NO	H
D	
F	0.60

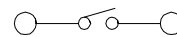
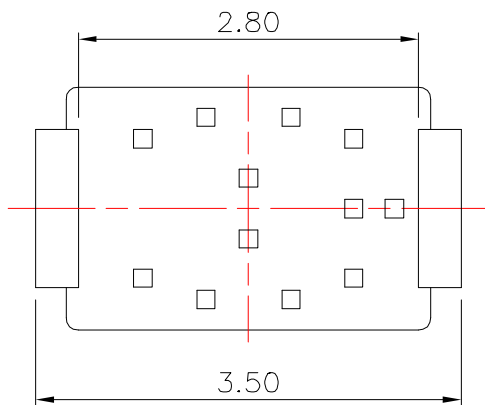

Circuit Diagram

Main technical specifications:

Rated load (额定负荷):	DC 12V 50mA			
Contact impedance (接触阻抗):	100m MAX			
Insulation impedance (绝缘阻抗):	100M MIN			
Welding resistance temperature (耐焊温度):	250 ± 5 ° 5s			
OPERATING LIFE (电气寿命):	100,000 cycles			
Usage temperature (使用温度):	-25 to 85			
Operating humidity (使用湿度):	85% RH			
Trip (行程):	0.15 ± 0.05mm			
Operating force (操作力):	1	90 ± 30gf	2	130 ± 30gf
	3	180 ± 50gf	4	250 ± 50gf
	5	350 ± 50gf	6	

public errand (公差) : ±0.2mm unit (单位) : mm

NO.2

LCZY ELECTRONICS(SHEN ZHEN)CO.,LTD

PART NAME		SWITCH		DRAWING	G.L CHEN	DWG.No.	LCZY
PART NO.		K2-1827SQ		CHECK	Z.LIU	REV.	A1
UNIT :	TOLERANCE OTHERWISE	UP TO 5	±0.2	ANGLE	APPROVAL	DATE	K2-09-2019
		ABOVE 5~30	±0.3				
mm		ABOVE 30	±0.5	0°±3'	SCALE	PAGE	1 OF 1
		ANGLE	±3'		2:1		

COPYRIGHT RESERVED,PLEASE DO NOT COPY.

K2-1827SQ- -