

RoHS

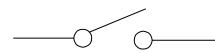
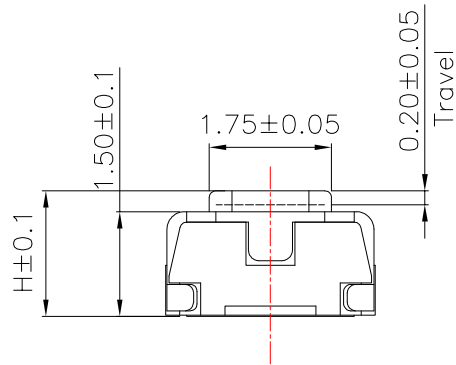
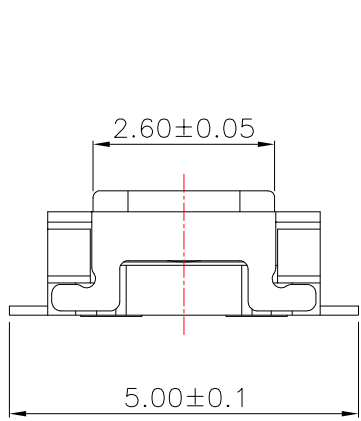

Circuit diagram

Height(高度) :

NO.1	
PART NO	H
D	1.8
F	2.0

Material:

Button 按钮	PBT/LCP耐温
Cover plate 盖板	铜 (镀银)
Shrapnel 弹片	不锈钢 (复银)
Base 基座	PBT/LCP耐温
Pin 引脚	磷铜 (镀银)

Main technical specifications:

Rated load(额定负荷):	DC 12V 50mA			
Contact impedance(接触阻抗):	100m MAX			
Insulation impedance(绝缘阻抗):	100M MIN			
Welding resistance temperature(耐焊温度):	250 ± 5 ° 5s			
OPERATING LIFE(电气寿命):	100,000 cycles			
Usage temperature(使用温度):	-25 to 85			
Operating humidity(使用湿度):	85% RH			
Trip(行程):	0.2 ± 0.1mm			
Operating force(操作力):	1	90 ± 30gf	2	130 ± 30gf
	3	180 ± 50gf	4	250 ± 50gf
	5	350 ± 50gf	6	

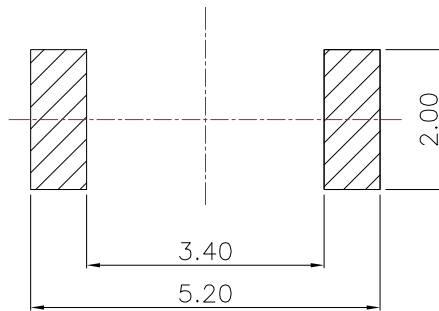
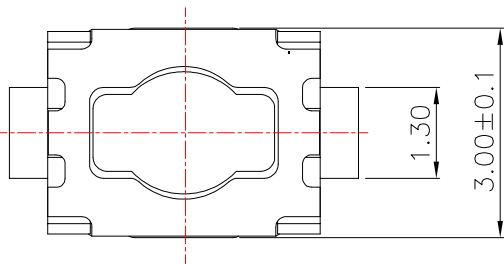

PCB Layout

public errand (公差) : ±0.2mm unit (单位) : mm

LCZY ELECTRONICS(SHEN ZHEN)CO.,LTD

COPYRIGHT RESERVED,PLEASE DO NOT COPY.

PART NAME		SWITCH		DRAWING	G.L CHEN	DWG.No.	LCZY
PART NO.		K2-1807SM		CHECK	Z.LIU	REV.	A1
UNIT : mm	TOLERANCE OTHERWISE	UP TO 5	±0.2	ANGLE	APPROVAL	DATE	K2-09-2019
		ABOVE 5~30	±0.3			SCALE	PAGE
		ABOVE 30	±0.5	0°±3'	2:1		
		ANGLE	±3'				

K2-1807SM- -