

RoHS

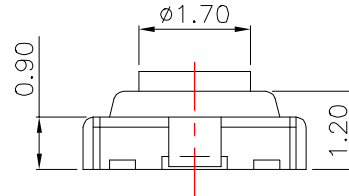
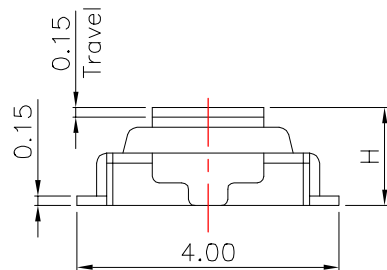
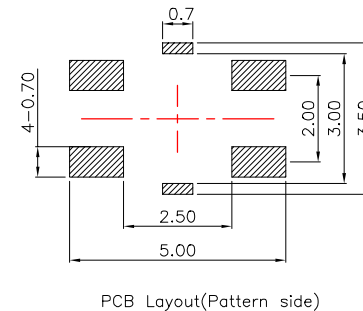
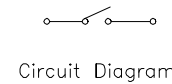
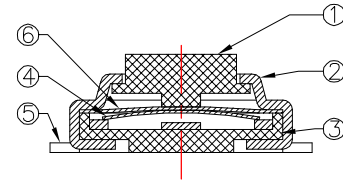
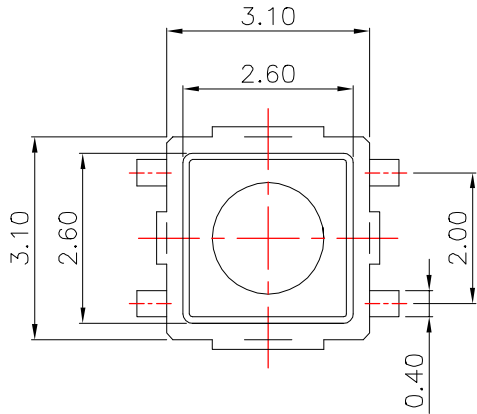

Height(高度) :

NO.1	
PART NO	H
D	1.5
F	2.0

Material:

Button 按钮	PPA/LCP耐温280
Cover plate 盖板	铁 (镀银)
Shrapnel 弹片	不锈钢 (复银)
Base 基座	PPA/LCP耐温280
Pin 引脚	磷铜 (镀银)

Main technical specifications:

Rated load(额定负荷):	DC 12V 50mA			
Contact impedance(接触阻抗):	100m MAX			
Insulation impedance(绝缘阻抗):	100M MIN			
Welding resistance temperature(耐焊温度):	250 ± 5 ° 5s			
OPERATING LIFE(电气寿命):	100,000 cycles			
Usage temperature(使用温度):	-25 to 85			
Operating humidity(使用湿度):	85% RH			
Trip(行程):	0.15 ± 0.05mm			
Operating force(操作力):	1	90 ± 30gf	2	130 ± 30gf
	3	180 ± 50gf	4	250 ± 50gf
	5	350 ± 50gf	6	

public errand (公差) : ±0.2mm unit (单位) : mm

NO.2

LCZY ELECTRONICS(SHEN ZHEN)CO.,LTD

PART NAME		SWITCH		DRAWING	G.L CHEN	DWG.No.	LCZY
PART NO.		K2-1177SW		CHECK	Z.LIU	REV.	A1
UNIT : mm	TOLERANCE	UP TO 5	±0.2	APPROVAL	DATE	K2-09-2019	
	OTHERWISE	ABOVE 5 ~30	±0.3				
		ABOVE 30	±0.5	SCALE	2:1	PAGE	1 OF 1
		ANGLE	±3°				

COPYRIGHT RESERVED,PLEASE DO NOT COPY.

K2-1177SW- -