

RoHS

Height(高度) :NO.1

	J		T
	I		S
	H		R
	G		Q
	F		P
	E		O
5.5	D		N
3.4	C		M
3.2	B		L
2.5	A		K
高度H(mm)	X=	高度H(mm)	X=

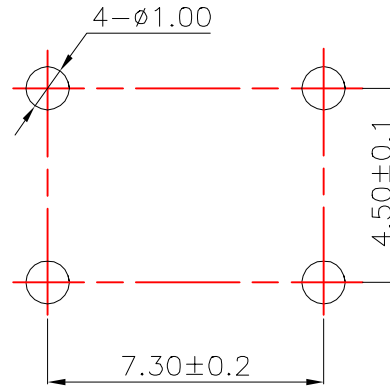
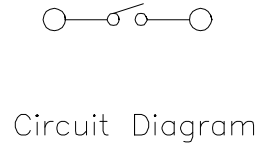
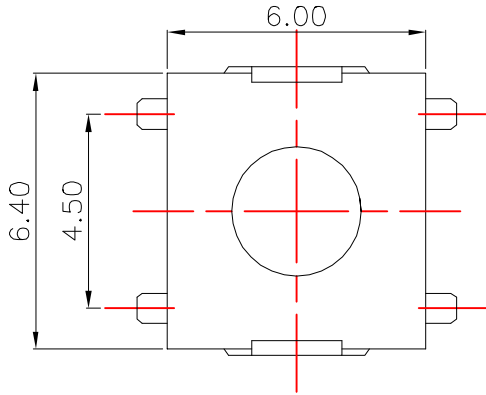

PCB Layout(Pattern side)

Material:

Button 按钮	PPA/LCP耐温280
Cover plate 盖板	铜 (镀银)
Shrapnel 弹片	不锈钢 (复银)
Base 基座	PPA/LCP耐温280
Pin 引脚	磷铜 (镀银)

Main technical specifications:

Rated load(额定负荷):	DC 12V 50mA
Contact impedance(接触阻抗):	100m MAX
Insulation impedance(绝缘阻抗):	100M MIN
Welding resistance temperature(耐焊温度):	250 ± 5 ° 5s
OPERATING LIFE(电气寿命):	100,000 cycles
Usage temperature(使用温度):	-25 to 85
Operating humidity(使用湿度):	85% RH
Trip(行程):	0.25 ± 0.1mm
Operating force(操作力):	1 90 ± 30gf 2 130 ± 30gf 3 180 ± 50gf 4 250 ± 50gf 5 350 ± 50gf 6

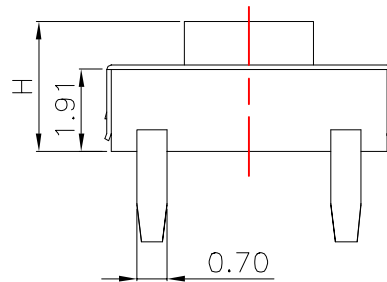
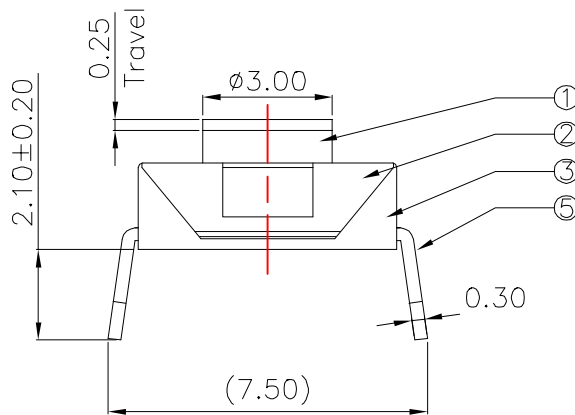

public errand (公差) : ±0.2mm unit (单位) : mm

LCZY ELECTRONICS(SHEN ZHEN)CO.,LTD

PART NAME		SWITCH		DRAWING		G.L CHEN		DWG.No.		LCZY	
PART NO.		K2-1157DP		CHECK		Z.LIU		REV.		A1	
UNIT :		TOLERANCE		ANGLE		APPROVAL		DATE		K2-09-2019	
mm		UP TO 5 ±0.2		0°±3'		SCALE		PAGE		1 OF 1	
		ABOVE 5~30 ±0.3				2:1					
		ABOVE 30 ±0.5									
		OTHERWISE ±3'									

COPYRIGHT RESERVED,PLEASE DO NOT COPY.

K2-1157DP