

RoHS

4 8

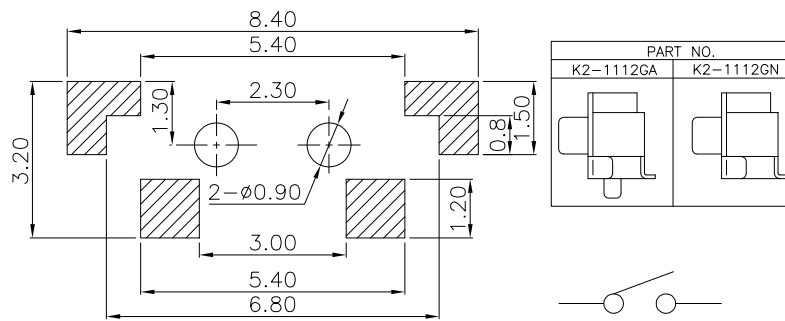
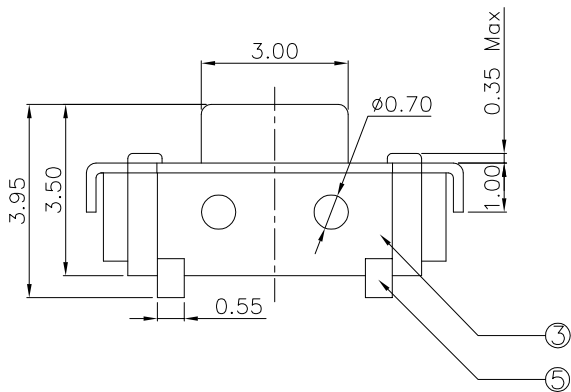

PCB Layout recommended

Circuit diagram

Height(高度) :

NO.1	
PART NO	H
D	3.5
F	3.8

Material:

Button 按钮	硅胶 (蓝色)
Cover plate 盖板	铜 (镀银)
Shrapnel 弹片	不锈钢 (复银)
Base 基座	PPA/LCP耐温280
Pin 引脚	磷铜 (镀银)

Main technical specifications:

Rated load(额定负荷):	DC 12V 50mA												
Contact impedance(接触阻抗):	100m MAX												
Insulation impedance(绝缘阻抗):	100M MIN												
Welding resistance temperature(耐焊温度):	250 ± 5 ° 5s												
OPERATING LIFE (电气寿命):	100,000 cycles												
Usage temperature (使用温度):	-25 to 85												
Operating humidity (使用湿度):	85% RH												
Trip(行程):	0.25 ± 0.1mm												
Operating force(操作力):	<table border="1"> <tr> <td>1</td> <td>90 ± 30gf</td> <td>2</td> <td>130 ± 30gf</td> </tr> <tr> <td>3</td> <td>180 ± 50gf</td> <td>4</td> <td>250 ± 50gf</td> </tr> <tr> <td>5</td> <td>350 ± 50gf</td> <td>6</td> <td></td> </tr> </table>	1	90 ± 30gf	2	130 ± 30gf	3	180 ± 50gf	4	250 ± 50gf	5	350 ± 50gf	6	
1	90 ± 30gf	2	130 ± 30gf										
3	180 ± 50gf	4	250 ± 50gf										
5	350 ± 50gf	6											

NO.2

public errand (公差) : ±0.2mm unit (单位) : mm

LCZY ELECTRONICS(SHEN ZHEN)CO.,LTD

COPYRIGHT RESERVED,PLEASE DO NOT COPY.

PART NAME		SWITCH		DRAWING	G.L CHEN	DWG.No.	LCZY
PART NO.		K2-1112GA		CHECK	Z.LIU	REV.	A1
UNIT :	TOLERANCE OTHERWISE	UP TO 5	±0.2	ANGLE	APPROVAL	DATE	K2-09-2019
		ABOVE 5~30	±0.3				
mm		ABOVE 30	±0.5	0°±3'	SCALE	PAGE	1 OF 1
		ANGLE	±3'				

K2-1112GA/K2-1112GN-

F

E

D

B

A