

RoHS

Height(高度) :NO.1

9.0	J	15.0	T
8.5	I	14.5	S
8.0	H	13.0	R
7.5	G	12.5	Q
7.0	F	12.0	P
6.5	E	11.5	O
6.0	D	11.0	N
5.5	C	10.5	M
5.0	B	10.0	L
4.3	A	9.5	K
高度H(mm)	X=	高度H(mm)	X=

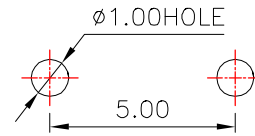
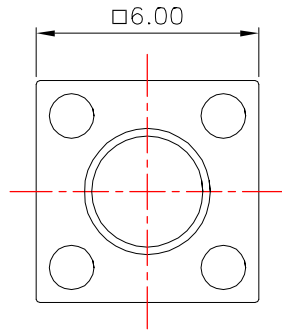

PCB Layout(Pattern side)

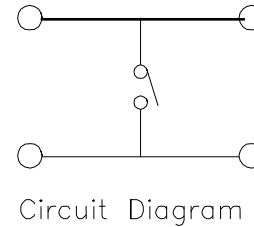
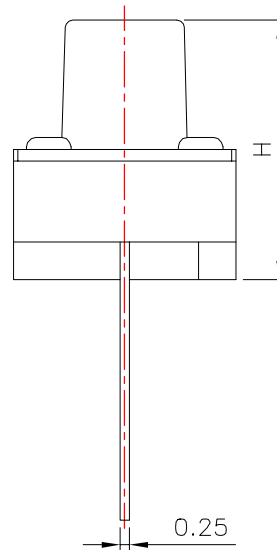
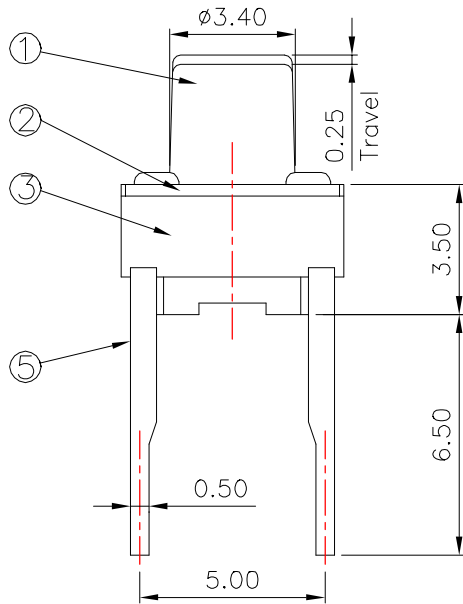

Material:

Button 按钮	PPA/LCP
Cover plate 盖板	铁 (镀银)
Shrapnel 弹片	不锈钢 (复银)
Base 基座	PPA/LCP
Pin 引脚	磷铜 (镀银)

Main technical specifications:

Rated load(额定负荷):	DC 12V 50mA												
Contact impedance(接触阻抗):	100m MAX												
Insulation impedance(绝缘阻抗):	100M MIN												
Welding resistance temperature(耐焊温度):	250 ± 5 ° 5s												
OPERATING LIFE(电气寿命):	100,000 cycles												
Usage temperature(使用温度):	-25 to 85												
Operating humidity(使用湿度):	85% RH												
Trip(行程):	0.25 ± 0.1mm												
Operating force(操作力):	<table border="1"> <tr> <td>1</td> <td>90 ± 30gf</td> <td>2</td> <td>130 ± 30gf</td> </tr> <tr> <td>3</td> <td>180 ± 50gf</td> <td>4</td> <td>250 ± 50gf</td> </tr> <tr> <td>5</td> <td>350 ± 50gf</td> <td>6</td> <td></td> </tr> </table>	1	90 ± 30gf	2	130 ± 30gf	3	180 ± 50gf	4	250 ± 50gf	5	350 ± 50gf	6	
1	90 ± 30gf	2	130 ± 30gf										
3	180 ± 50gf	4	250 ± 50gf										
5	350 ± 50gf	6											

public errand (公差) : ±0.2mm unit (单位) : mm

NO.2

LCZY ELECTRONICS(SHEN ZHEN)CO.,LTD

PART NAME		SWITCH		DRAWING	G.L CHEN	DWG.No.	LCZY
PART NO.		K2-1104DZ		CHECK	Z.LIU	REV.	A1
UNIT : mm	TOLERANCE	UP TO 5	±0.2	APPROVAL	DATE	K2-09-2019	
	OTHERWISE	ABOVE 5~30	±0.3				
		ABOVE 30	±0.5	SCALE	PAGE	1 OF 1	
		ANGLE	0°±3'				

COPYRIGHT RESERVED,PLEASE DO NOT COPY.

K2-1104DZ- -