

RoHS

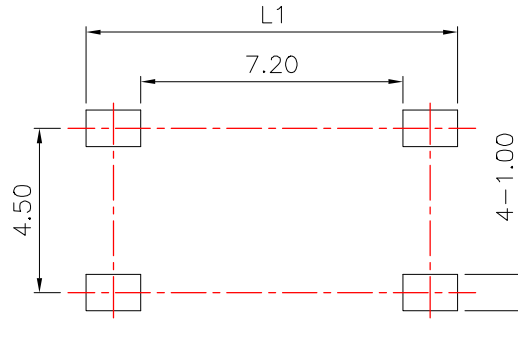

PCB Layout(Pattern side)

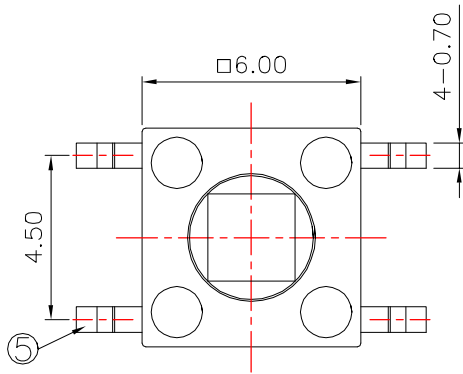
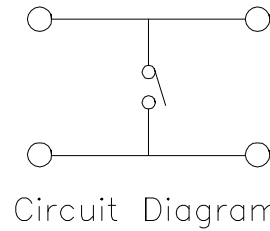

Circuit Diagram

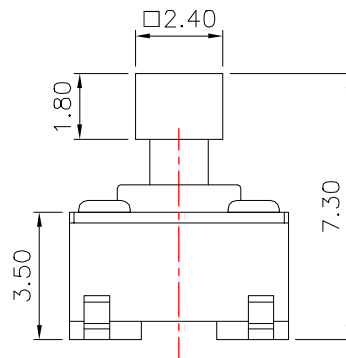
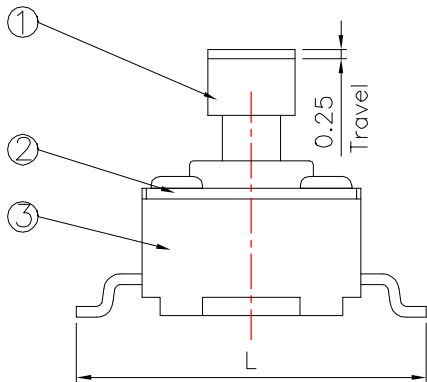

Height(高度) :

NO.1	
PART NO	H
D	7.3
F	

NO.3		
PART NO	L	L1
A	8	10
B	8.5	11
C	9	11
D	9.5	12
E	10	12

Material:

Button 按钮	PPA/LCP
Cover plate 盖板	铁 (镀银)
Shrapnel 弹片	不锈钢 (复银)
Base 底座	PPA/LCP
Pin 引脚	磷铜 (镀银)

Main technical specifications:

Rated load(额定负荷):	DC 12V 50mA
Contact impedance(接触阻抗):	100m MAX
Insulation impedance(绝缘阻抗):	100M MIN
Welding resistance temperature(耐焊温度):	250 ± 5 ° 5s
OPERATING LIFE (电气寿命):	100,000 cycles
Usage temperature (使用温度):	-25 to 85
Operating humidity (使用湿度):	85% RH
Trip(行程):	0.35 ± 0.1mm
Operating force(操作力):	1 90 ± 30gf 2 130 ± 30gf 3 180 ± 50gf 4 250 ± 50gf 5 350 ± 50gf 6

public errand (公差) : ±0.2mm unit (单位) : mm

LCZY ELECTRONICS(SHEN ZHEN)CO.,LTD

COPYRIGHT RESERVED,PLEASE DO NOT COPY.

PART NAME		SWITCH		DRAWING	G.L CHEN	DWG.No.	LCZY
PART NO.		K2-1102ST		CHECK	Z.LIU	REV.	A1
UNIT : mm	TOLERANCE	UP TO 5	±0.2	APPROVAL	DATE	K2-09-2019	K2-09-2019
	OTHERWISE	ABOVE 5~30	±0.3				
		ABOVE 30	±0.5	SCALE	2:1	PAGE	1 OF 1
		ANGLE	±3°				

K2-1102ST- - -